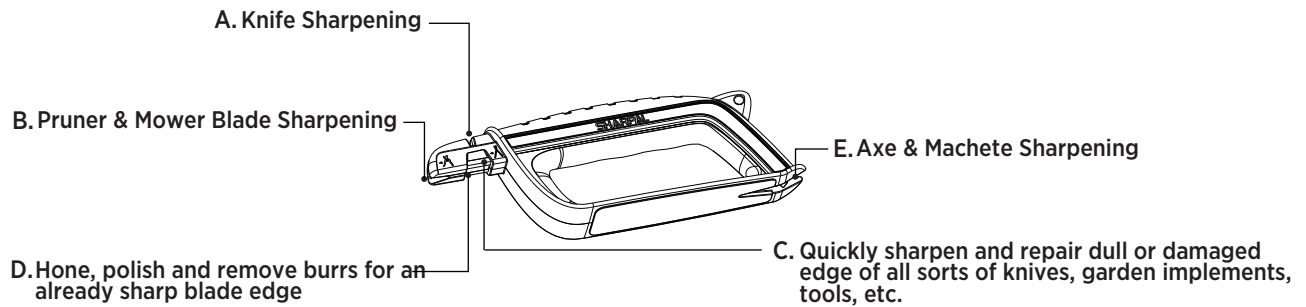

User Manual

**A - KNIFE SHARPENING INSTRUCTION:**

1. Hold the sharpener with your left hand on a flat, stable surface.
2. Insert blade fully and vertically into V-Notch carbide sharpening slot A at a 90 degree angle to the sharpener. Gently with light pressure pull the knife blade from heel to tip in direction of indicator arrows. (See Fig. 1)

Note: Light pressure is sufficient when using the knife sharpener. Heavy pressure might cause to lose control of the knife and could cause possible injury. Carefully and gradually increase pressure until the desired result is realized. The V-Notch carbide sharpening slot A is for dull or damaged edge that requires new edge setting. If need fine honing of slightly dull edge, please sharpen with ceramic rod D. Try to sharpen with ceramic rod D firstly for your valuable knives.

3. Repeat above action until blade is sharp. **Always pull the blade through the sharpening slot from heel to tip, never back and forth.**

B - PRUNER SHARPENING INSTRUCTION:

Most pruning shears, loppers and mower have blades that are only beveled on one side of the blade. Only sharpen the side of each blade that has a bevel. **This single carbide sharpening slot B is NOT designed to put an edge on a blade with no initial bevel or sharpen a double-beveled or serrated edge blade. It is to be used for maintaining sharpness and edge quality of blades with a single-bevel on one side of the blade only.**

1. Secure the blade of your pruners, loppers or mower that you want to sharpen as much as possible with the cutting edge exposed.
2. Position the head of the sharpener over the heel of the blade. Then lower the sharpener down so that the cutting edge is resting in the bottom of the V-Notch slot. **Make sure the angled carbide blade in the V-Notch is aligned with the beveled side of blade.** Hold the sharpener as parallel to the cutting edge as possible. Then apply moderate downward pressure to pull the sharpener across the cutting edge from heel to tip in direction of indicator arrows. (See Fig. 2). Maintain constant pressure and follow the contour of the blade as you pull.
3. Repeat above action until blade is sharp. **Always pull the sharpener across the blade from heel to tip, never back and forth.**

C - HEDGE SHEARS SHARPENING INSTRUCTION:

Including but not limited to hedge shears, carbide C can sharpen all sorts of knives, garden implements, scissors, tool edge, etc. Hold the sharpener at a slight angle to the blades. Stroke the sharpener along the cutting edge from heel to tip in direction of indicator arrows. (See Fig. 3)

Angle between the edge being sharpened and carbide C should be approximately 20 degrees. (See Fig. 4) Always maintain the angle and stroke this sharpener repeatedly along each side of the edge until the desired sharpness is obtained. Maintain constant pressure and follow the contour of the blade as you stroke. **For those single-beveled blades such as blades of hedge shears, pruner & mowers, only sharpen the side of each blade that has a bevel.**

D - SCISSORS HONING INSTRUCTION:

Including but not limited to scissors, ceramic rod D can hone and realign all sorts of knives, garden implements, tool edge, etc. Hold the sharpener at a slight angle to the blades. Stroke the sharpener along the cutting edge from heel to tip in direction of indicator arrows. (See Fig. 5)

Angle between the edge being sharpened and ceramic rod D should be approximately 20 degrees. (See Fig. 6) Always maintain the angle and stroke this sharpener repeatedly along each side of the edge until the desired sharpness is obtained. Maintain constant pressure and follow the contour of the blade as you stroke. **For those single- beveled blades such as blades of scissors, hedge shears, pruner & mowers, only sharpen the side of each blade that has a bevel.**

E - AXE SHARPENING INSTRUCTION:

1. Secure axe, hatchet or machete blade by clamping it in a vise with cutting edge exposed.
2. Position the head of the sharpener over one end of the blade. Then lower the sharpener down so that the cutting edge is resting in the bottom of the V-Notch slot E. Hold the sharpener as parallel to the cutting edge as possible. Then apply moderate downward pressure to pull the sharpener across the cutting edge from one end to the other in direction of indicator arrows. (See Fig. 7) Maintain constant pressure and follow the contour of the blade as you pull.
3. Repeat above action until blade is sharp. **Always pull the sharpener across the blade from one end to the other, never back and forth.**

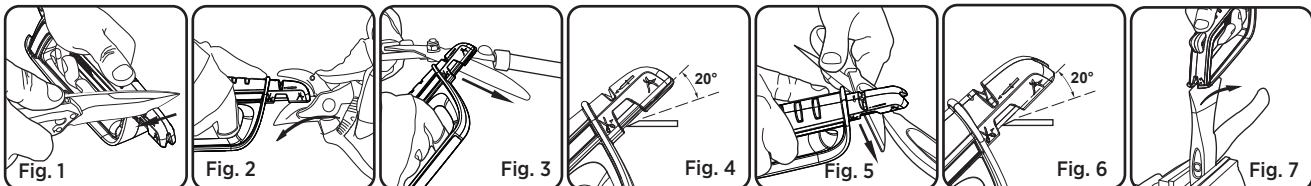
**MAINTENANCE:**

1. Clean the exterior with a damp soft cloth.
2. Oil or other lubricating liquid is not necessary.

CAUTION: Always wear gloves and eye protection when sharpening a blade with this product. Always keep all fingers behind the finger guard and never place free hand on top of the sharpener during use.

WARNINGS: This product is not a toy. Keep out of the reach of children.

- Watch its demo video on YouTube: bit.ly/103Nvideo

Or scan QR code

- Each SHARPAL product is warranted to be free from defects in material and workmanship for **3 years** from the date of purchase under normal wear and tear, except for damage caused by misuse or alteration. **THIS WARRANTY APPLIES ONLY TO NON-INDUSTRIAL OR NON-COMMERCIAL USE.** If you want to make a warranty claim, please contact us through SHARPAL website or send an email directly to warranty@sharpal.com.

